

HOCHLEISTUNGS-GELENKKÖPFE
Mit integrierter Gleitlagerung,
Maßreihe K, Innengewinde,
Anschlussmaße nach DIN ISO
12240-4 und DIN ISO 8139

HEAVY-DUTY ROD ENDS
 With integral spherical-plain bearing, series K, female thread, according to DIN ISO 12240-4 and thread according to DIN ISO 8139

→ **Sonderanfertigungen auf Anfrage**
 → Custom made products on request

Gehäuse:
 Geschmiedeter Einsatzstahl, vergütet, Oberfläche galvanisch verzinkt, Cr VI-frei
Lagerschale DURBAL-Glide:
 Polyamid-PTFE-Glasfaser-Compound
Gelenkkugel:
 Wälzlagerstahl, gehärtet, geschliffen, poliert, Lauffläche hartverchromt
Wartung:
 Wartungsfrei
Toleranzen:
 Seite 050 – 057

Housing:
 Forged steel, tempered, surface galvanized, free of Cr VI
Race DURBAL-Glide:
 Polyamid-PTFE-fibreglass-Compound
Joint ball:
 Ball bearing steel, hardened, ground, polished and hard chromium plated
Maintenance:
 Maintenance-free
Tolerances:
 Page 050 – 057

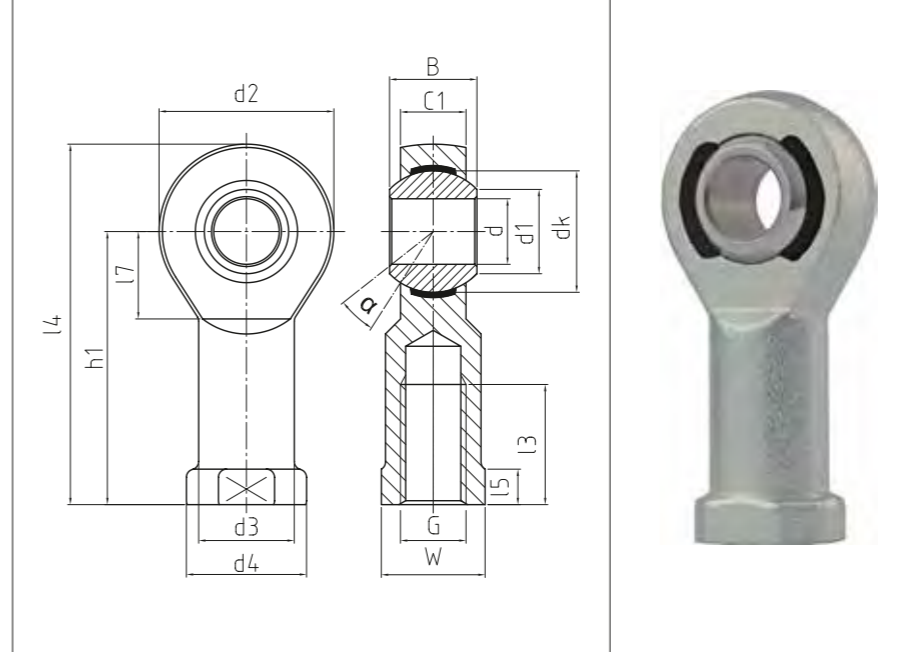

BEF

Hochleistungs-Gelenkköpfe
 Heavy-duty rod ends

CLASSIC Line X

Bestellnummer Order number			Abmessungen Measurements [mm]													Kippwinkel Tilt angle	Gewicht Weight	Tragzahlen Basic load rating		Radiale Lagerluft Radial clearance				
Typ Type	Rechtsgewinde Right hand thread	Linksgewinde Left hand thread	d	G	B	C1	h1	d1	d2	d3	d4		dk	l3	l4	l5	l7	W	α [°]	[kg]	dyn C [kN]	stat Co [kN]	CN [µm]	d
BEF 05 - 20	-501	-502	5	M 5	8	6	27	7,7	18	9	11		11,06	10	36	4	10	9	13	0,018	3,9	11,9	0 - 10	5
BEF 05 - 21	-501	-502	5	M 4	8	6	27	7,7	18	9	11		11,06	10	36	4	10	9	13	0,018	3,9	11,9	0 - 10	5
BEF 06 - 20	-501	-502	6	M 6	9	6,75	30	8,9	20	10	13		12,65	12	40	5	10	11	13	0,024	4,6	14,1	0 - 10	6
BEF 08 - 20	-501	-502	8	M 8	12	9	36	10,3	24	12,5	16		15,82	16	48	5	12	14	14,5	0,045	7	21,1	0 - 10	8
BEF 10 - 20	-501	-502	10	M 10	14	10,5	43	12,9	28	15	19		19	20	57	6,5	15	17	13,5	0,074	10,4	30,2	0 - 10	10
BEF 10 - 21	-501	-502	10	M 10 x 1,25	14	10,5	43	12,9	28	15	19		19	20	57	6,5	15	17	13,5	0,074	10,4	30,2	0 - 10	10
BEF 12 - 20	-501	-502	12	M 12	16	12	50	15,4	32	17,5	22		22,17	22	66	6,5	16	19	13	0,109	12,4	36,7	0 - 10	12
BEF 12 - 21	-501	-502	12	M 12 x 1,25	16	12	50	15,4	32	17,5	22		22,17	22	66	6,5	16	19	13	0,109	12,4	36,7	0 - 10	12
BEF 14 - 20	-501	-502	14	M 14	19	13,5	57	16,8	36	20	25		25,35	25	75	8	20	22	16	0,155	15,4	45,5	0 - 10	14
BEF 16 - 20	-501	-502	16	M 16	21	15	64	19,3	42	22	27		28,52	28	85	8	22	22	15,5	0,233	22,4	59,6	0 - 10	16
BEF 16 - 21	-501	-502	16	M 16 x 1,5	21	15	64	19,3	42	22	27		28,52	28	85	8	22	22	15,5	0,233	22,4	59,6	0 - 10	16
BEF 18 - 20	-501	-502	18	M 18 x 1,5	23	16,5	71	21,8	46	25	31		31,7	32	94	10	24	27	15	0,31	26,3	69,7	0 - 10	18
BEF 20 - 20	-501	-502	20	M 20 x 1,5	25	18	77	24,3	50	27,5	34		34,87	33	102	10	26	30	14,5	0,386	30,8	82,2	0 - 10	20
BEF 22 - 20	-501	-502	22	M 22 x 1,5	28	20	84	25,8	54	30	38		38,05	37	111	12	26	32	15,5	0,52	38,2	95,6	0 - 10	22
BEF 25 - 20	-501	-502	25	M 24 x 2	31	22	94	29,5	60	33,5	42		42,8	42	124	12	30	36	15	0,705	45,4	118,6	0 - 10	25
BEF 30 - 20	-501	-502	30	M 30 x 2	37	25	110	34,8	70	40	50		50,75	51	145	15	35	41	17	1,084	55	145,6	0 - 10	30
BEF 30 - 21	-501	-502	30	M 27 x 2	37	25	110	34,8	70	40	50		50,75	51	145	15	35	41	17	1,084	55	145,6	0 - 10	30

* Auf Anfrage mit DURBAL-Coat Beschichtung (Zink-Nickel) und Edelstahl-Gelenkkugel
 * On request with DURBAL-Coat (Zinc-Nickel) and stainless steel joint ball